



GigaSpire BLAST u4hm (GM1028H) Installation Guide

June 2024

#220-01346-12

Contents

About this Guide	3
Chapter 1: GigaSpire BLAST u4hm (GM1028H) Product Overview	9
Introducing the GigaSpire BLAST u4hm	10
Product Dimensions	11
Exploring Product Interfaces	12
Mounting Options	13
Powering Options.....	14
Agency Listings	16
Installation Variables.....	18
Chapter 2: Installing the GM1028H GigaSpire BLAST Satellite.....	21
Unpacking the GigaSpire BLAST GM1028H	22
Installing Power and Network Cables	23
Identifying the Installation Location.....	25
Installing the System on a Wall	27
Installing the System on a Pole	30
Grounding the Unit	33

Chapter 3: Final Setup and Activation..... 35

Powering Up the System 36

Replacing Removed Covers 37

Sealing Cable Entry Locations 38

Appendix 39

System LED Behavior..... 39

System Specifications 41

About this Guide

This document provides the installation practice for the Calix GigaSpire BLAST GM1028H (u4hm) outdoor satellite system.

Note that there are two separate models:

1. GM1028H GigaSpire BLAST u4hm outdoor ONU. This item is marketed in North America.
2. GM1028H-2 GigaSpire BLAST u4hm-2 outdoor ONU. This item is marketed in International markets.

In this guide, the GM1028H is referenced while the GM1028H-2 is also covered but not referenced.

Intended Audiences

This document is intended for use by network planning engineers, outside plant engineers, and field/craft personnel responsible for installation and maintenance of Calix premises equipment.

Safety and Regulatory Information

Federal Communications Commission (FCC) Statement

- This equipment has been tested and found to comply with the limits for a Class B digital device, pursuant to Part 15 of the FCC Rules. These limits are designed to provide reasonable protection against harmful interference in a residential installation. This equipment generates, uses and can radiate radio frequency energy and, if not installed and used in accordance with the instructions, may cause harmful interference to radio communications. However, there is no guarantee that interference will not occur in a particular installation. If this equipment does cause harmful interference to radio or television reception, which can be determined by turning the equipment off and on, the user is encouraged to try to correct the interference by one of the following measures:
 - Reorient or relocate the receiving antenna.
 - Increase the separation between the equipment and receiver.
Connect the equipment into an outlet on a circuit different from that to which the receiver is connected.
 - Consult the dealer or an experienced radio/TV technician for help.

FCC Caution: Any changes or modifications not expressly approved by the party responsible for compliance could void the user's authority to operate this equipment.

- Professional installation is required.

IMPORTANT NOTE: FCC Radiation Exposure Statement

This equipment complies with FCC radiation exposure limits set forth for an uncontrolled environment. This equipment should be installed and operated with a minimum distance of 20cm between the radiator & your body.

This device contains license-exempt transmitter(s)/receiver(s) that comply with Innovation, Science and Economic Development Canada's license-exempt RSS(s). Operation is subject to the following two conditions:

- (1) This device may not cause interference.
- (2) This device must accept any interference, including interference that may cause undesired operation of the device.

Cet appareil contient des émetteurs / récepteurs exempts de licence qui sont conformes au (x) RSS (s) exemptés de licence d'Innovation, Sciences et Développement économique Canada. L'opération est soumise aux deux conditions suivantes:

- (1) Cet appareil ne doit pas provoquer d'interférences.
- (2) Cet appareil doit accepter toute interférence, y compris les interférences susceptibles de provoquer un fonctionnement indésirable de l'appareil.

IMPORTANT NOTE: IC Radiation Exposure Statement

This equipment complies with IC RSS-102 radiation exposure limits set forth for an uncontrolled environment. This equipment should be installed and operated with a minimum distance of 30cm between the radiator & your body.

Cet équipement est conforme aux limites d'exposition aux rayonnements IC établies pour un environnement non contrôlé. Cet équipement doit être installé et utilisé avec un minimum de 30cm de distance entre la source de rayonnement et votre corps.

This document uses the following safety notice conventions.



DANGER! Danger indicates the presence of a hazard that will cause severe personal injury or death if not avoided.

DANGER! Danger indique la présence d'un danger qui entraînera des blessures graves ou la mort s'il n'est pas évité.



WARNING! Warning indicates the presence of a hazard that can cause severe personal injury if not avoided.

ATTENTION! Avertissement indique la présence d'un danger pouvant entraîner des blessures graves s'il n'est pas évité.



CAUTION! Caution indicates the presence of a hazard that can cause minor to moderate personal injury if not avoided.

MISE EN GARDE! Attention indique la présence d'un danger qui peut causer des blessures légères à modérées s'il n'est pas évité



ALERT! Alert indicates presence of a hazard that can cause damage to equipment or software, loss of data, or service interruption if not avoided.

ALERTE! L'alerte indique la présence d'un danger susceptible d'endommager l'équipement ou les logiciels, de perdre des données ou d'interrompre le service s'il n'est pas évité.



DANGER! CLASS 1 LASER PRODUCT. INVISIBLE LASER RADIATION MAY BE PRESENT. Fiber optic radiation can cause severe eye damage or blindness. Do not look into the open end of an optical fiber.

DANGER! PRODUIT LASER DE CLASSE 1. UN RAYONNEMENT LASER INVISIBLE PEUT ÊTRE PRÉSENT. Le rayonnement de la fibre optique peut causer de graves lésions oculaires ou la cécité. Ne regardez pas dans l'extrémité ouverte d'une fibre optique.

Important Safety Instructions

When using your equipment, basic safety precautions must always be followed to reduce the risk of fire, electric shock, and injury to persons, including the following:

- Do not use this product near water. For example, near a bathtub, washbowl, kitchen sink, or laundry tub, in a wet basement, or near a swimming pool.
- Use only the power cord indicated in this manual.
- For external power supplies, the external power supply used in this device is to be Class II or a Limited Power Source (LPS) power supply.



Chapter 1

GigaSpire BLAST u4hm (GM1028H) Product Overview

This chapter introduces the Calix GigaSpire BLAST u4hm (GM1028H) and BLAST u4hm-2 outdoor mesh Wi-Fi satellite system and provides an overview of installation considerations.

Topics Covered

This chapter covers the following topics:

- *Introducing the GigaSpire BLAST u4hm* (on page 9)
- *Product Dimensions* (on page 11)
- *Exploring the Product Interfaces* (on page 11)
- *Powering Options* (on page 14)
- *Mounting Options* (on page 13)
- *Installation Considerations* (on page 17)

Introducing the GigaSpire BLAST u4hm

The Calix GigaSpire BLAST u4hm (GM1028H) is a new generation, dual-band, outdoor PoE or local powered Wi-Fi 6 mesh system, ideal for residential applications, bringing high-bandwidth services outdoors to the barn, patio, pool, and more. It features the latest Wi-Fi 6 technology, offering the optimal Wi-Fi experience. Besides supporting data and video services, this intelligent, high-performance system has GE LAN and WAN interface, allowing it to support Gigabit throughput for video and data services.

The GigaSpire BLAST u4hm is a dual-band, outdoor PoE or local powered Wi-Fi 6 system that leverages the 2.4 and 5 GHz spectrum. Using a Gigabit ethernet interface supporting either WAN or LAN allows broadband service providers (BSPs) to provide high bandwidth for the most demanding environments.

With integrated Power over Ethernet (PoE), the GigaSpire BLAST u4hm can be placed in an optimal location even without power availability. Coupled with the Calix GigaPro GPR8802x, the GigaSpire BLAST u4hm can be powered via an ethernet cable. In addition, the GigaSpire BLAST u4hm can also be powered locally (with a traditional power adapter), offering the ultimate outdoor location flexibility.

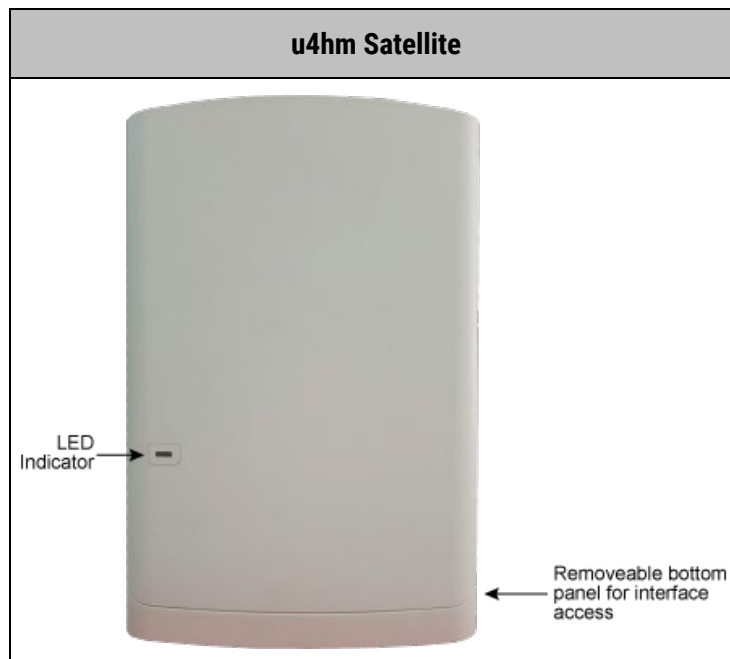

Key attributes of the hardened u4hm include the following:

- Environmentally hardened system for outdoor operation in extreme conditions
- Layer 2 bridge and Layer 3 routing for High-Speed Internet (HSI) data and IPTV video services
- 2.4 GHz and 5 GHz 802.11ax (Wi-Fi 6) certified, 802.11a/b/g/n/ac compatible

- WPA/WPA2/WPA3; WEP 64/128-bit encryption
- Dynamic Mesh: load balancing, band/node steering; interference management
- Remote WAN side GUI access
- Gigabit ethernet LAN/WAN interface; single port of multi-rate 10/100/1000 BASE-T ethernet, auto-negotiating for residential IPTV and data services
- Dynamic Mesh: load balancing, band/node steering; interference management
- Supports a Power of ethernet (PoE) input power option on its Gigabit WAN port to operate as a PoE Powered Device (PD); or can be powered locally with a traditional AC/DC power adapter.

Product Dimensions

Dimensions for the GigaSpire BLAST u4hm are included here for reference.

Note: The GM1028H must be wall or pole mounted using the appropriate mounting bracket.

Note: The u4hm includes the wall mount bracket affixed to the back of the unit.

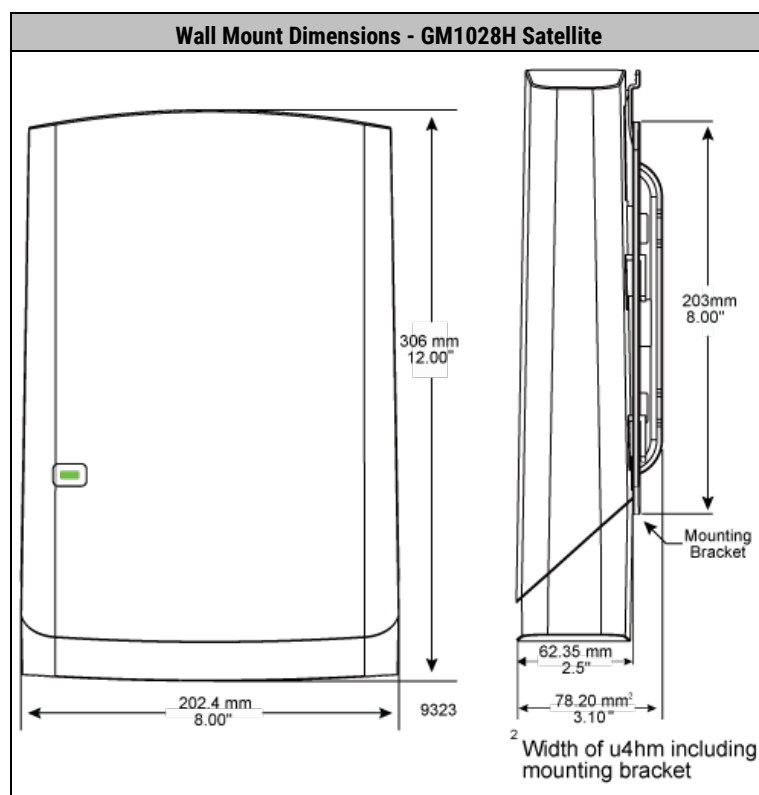

Exploring Product Interfaces

The GM1028H uses a combination of covers and cut-outs to keep the incoming fiber protected and dry.

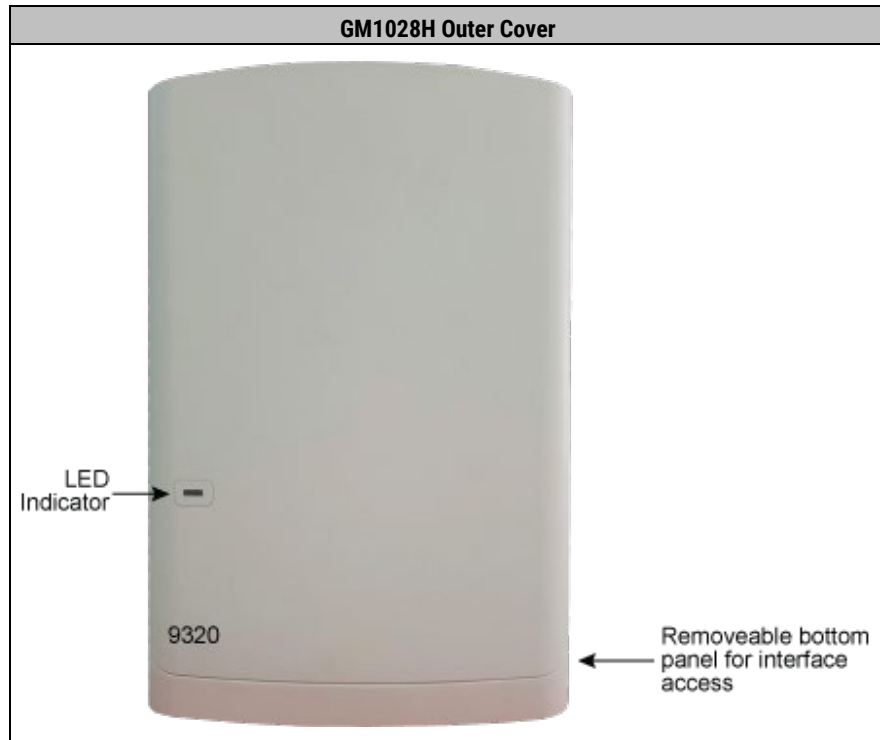

With the bottom cover removed a partial view of the ports can be seen.

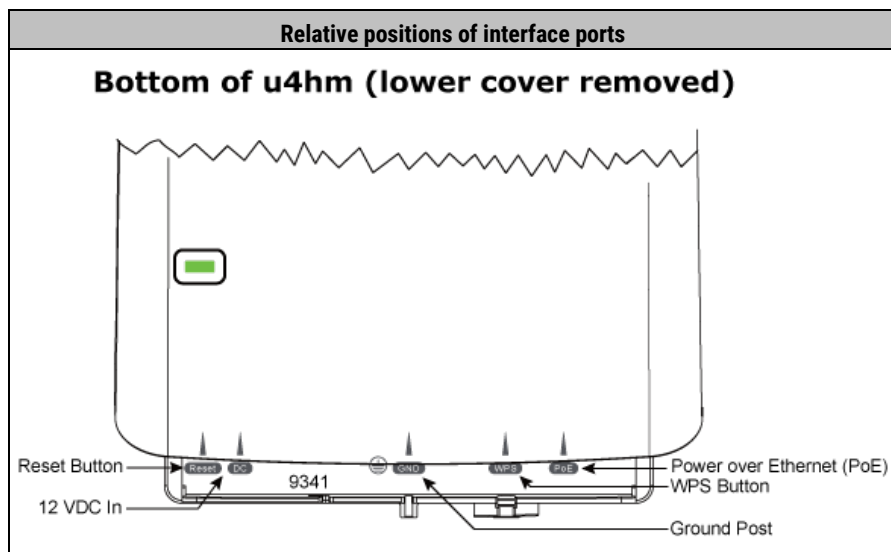

By tilting the GM1028H downward, the bottom surface of the satellite can be seen. The image below provides information on interface ports and their functions.

Note: The view below shows the GM1028H with the Wall Mount Bracket already attached.

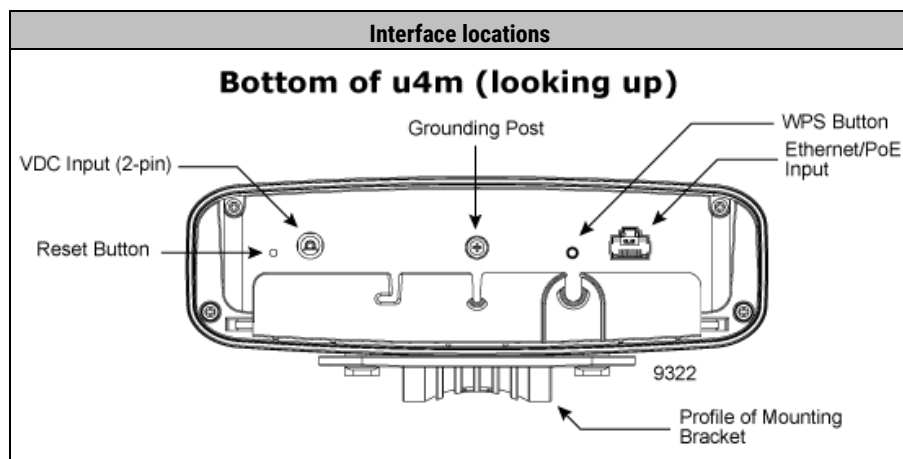

Mounting Options

Currently, there are two methods for mounting the u4hm:

Wall Mount (on page 26) - The u4hm wall mount bracket is standard equipment on the GM1028H. *Mounting instructions* (on page 26) are included in this guide.

Pole Mount (on page 29) - A pole mount bracket kit can be ordered separately.

- 100-05967 Pole mount bracket for GigaSpire BLAST GM1028H (u4hm)

Additional Mounting Considerations

From a best practice's standpoint, keep the following in mind:

- Calix recommends mounting the BLAST u4hm as high as practical for Wi-Fi performance reasons. However, this deployment scenario still mandates that an AC power outlet is located within the power cord distance of the Wi-Fi source. If installing in a greenfield environment (initial installation), plan on placing the GM1028H within 10 feet of the power supply. As an alternative, longer power cords are available to extend the distance between the u4hm and the power supply.
- Calix also recommends keeping cabling neat and well secured wherever possible. A tidy installation allows for increased safety and an overall neater appearance. Common tools used for this purpose include cable ties and velcro straps for routing cable out of the way. Also, custom made wall plates may be used where most cabling is hidden behind a wall.
- 27 inch/pounds of torque or less should be used when tightening fasteners to both the bracket and the u4hm.

Powering Options

The GigaSpire u4hm system supports two options for power:

- Local AC power: You can power the system via a standard AC power outlet using a Calix power adapter cable.
- PoE: You can line-power the system via the ethernet uplink data cable using a PoE injector or PoE switch.

Use the local power option or PoE option for each system, **but not both at the same time.**

Local Power Option

The u4hm system accepts local power using a Calix-supplied adapter cable that plugs into any standard AC power outlet. The DC end of the adapter cable has a two-pin barrel connector to connect to the u4hm local power interface.

For outdoor applications, use the outdoor/indoor power cable:

- 100-05866 - Outdoor/indoor power adapter cable; 12 V, 3A, Type B (3-prong), I-temp rated; 16-foot (491 cm) length)



Note: Use only a Calix-supplied power cable, as only these cables have been tested and approved for use with this product.

PoE Power Option

The GigaSpire u4hm system is an 802.3at PoE Powered Device (PD). The u4hm accepts PoE power via an ethernet data cable connected to its WAN uplink port.

To employ the PoE option, you must provide the following:

1. Standard PoE power sourcing equipment (PSE) – typically a PoE injector¹ – to apply power to the ethernet cable. Install the PoE injector at an indoor location between the RG system and the u4hm satellite.
2. An ethernet cable to provide both the PoE power input and data uplink connection. Use Cat6 ethernet cable; maximum 328-foot (100m) length.
3. (Recommended) An Ethernet Surge Protector (ESP) device installed inline on the ethernet cable, to provide proper grounding for the cable and to protect equipment from damage due to electrical surge events.

See diagram below for proper installation and arrangement of these PoE elements.

¹ **Note:** As a standards-based solution, the GigaSpire u4hm system can accept PoE power from any IEEE 802.3at compliant PSE. Performance may vary by manufacturer. To ensure the best possible performance, Calix recommends using the Calix PoE injector (100-06005) because it has been thoroughly tested for all supported use cases.

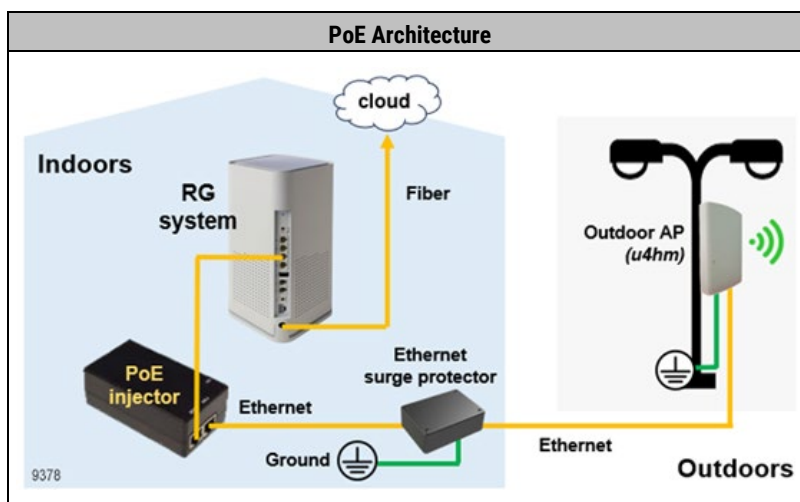

Agency Listings

FCC WARNING: These devices comply with Part 15 of the FCC Rules and Regulations. Operation is subject to the following conditions.

This device may not cause harmful interference, and, this device must accept any interference received, including interference that may cause undesired operation.

These devices have been tested and found to comply with the limits for a Class B digital device pursuant to Part 15 of the FCC Rules and Regulations. These limits are designed to provide reasonable protection against harmful interference when this equipment is operated in a commercial environment.



This equipment generates, uses, and can radiate radio frequency energy and, if not installed and used in accordance with the instructions in this guide, may cause harmful interference to radio and television communications.

Hazardous Materials

There are no hazardous materials identified for the GigaSpire GM1028H.

Application Standards

Following is a list of standards that apply to this product:

Standards		
FCC Part 15, Sub Part B, class B	UL 62368-1	EN 300 328
CAN ICES-003 Class B	CSA C22.2 No. 62368-1	EN 301 893
ANSI C63.4	IEC 62368-1	EN 301 489-1
FCC Part 15.247	ITU-T K21	EN 301 489-17
FCC Part 15.203	ITU-T K44	EN 55032 Class B
FCC Part 15.207	EN 62368-1	EN 61000-3-2
FCC Part 15.209	IC: 4009A-U4X	EN 61000-3-3
FCC ID: 2ABLK-U4X	EN 62311	EN 50581
RSS 102	CE / RED, RoHS, WEEE, Energy	USB 2.0 Type A
RSS 247	Telcordia GR-63	EN 50564
FCC Part 15.407	Telcordia-GR-1089	CISPR 32 Class B
NEC (National Electrical Code)	Telcordia GR-950	IEEE: 802.3, 802.3AB, 302.3U, 802.11p, 802.11Q
Telcordia GR-909	Telcordia GR-1244	RCM
Telcordia GR-49	Telcordia GR-2890	CISPR-22
Wi-Fi Alliance Certified 802.11ax		
Wi-Fi DFS Certified		

Radiated Emissions

This Class-B digital device complies with radiated emissions requirements as defined in Canadian ICES-003.

Product Compliance

GigaSpire BLAST systems have achieved National Fire Protection Association (NFPA) compliance.

Conformité du Produit

Les systèmes GigaSpire BLAST sont maintenant conformes à la National Fire Protection Association (NFPA).

Power Supply

The unit must be powered by a listed power adapter or DC power source marked "LPS" (Limited Power Source) and rated output between 12 VDC, 3 A minimum, TMA = 40 degrees Celsius minimum. If additional help is needed with implementing a power supply, please contact your local Calix service professional.

Note: A waterproof ethernet connector and cable are required when powered by PoE.

An external power supply is included with the following rating:

- **GigaSpire BLAST** GM1028H Input voltage: 12 VDC (nominal), 10 VDC (min.), 15 VDC (max)
- External Power Adapter: 12 VDC, 3 A
- PoE 802.3at PD



DANGER! Using non-approved or incorrect power adapters can result in injury.

DANGER! L'utilisation d'adaptateurs d'alimentation non approuvés ou incorrects peut entraîner des blessures.

Note: When using the standard power adapter, units will be inoperable after loss of main power.

Installation Variables

General Guidelines

Follow these general guidelines and practices:

- Read this document completely before starting any installation activities.
- Determine the system powering method to use for your installation, from among two options. See *Powering Options* (on page 14) and *Identifying the Installation Location* (on page 24) for details and guidance.
- Determine the system mounting method to use for your installation, from among two options. See *Mounting Options* (on page 13) and *Identifying the Installation Location* (on page 24) for details and guidance.
- Follow standard safety precautions when performing installation tasks.
- Keeping all cabling neat and secured for safety and strain relief. Use cable ties, screw clips, and velcro straps for dressing cables as needed.

Network Uplink

The u4hm system is equipped with a 1GE WAN ethernet port for uplink connections to the network. Connect the system to the network following these guidelines:

Connect the system to the network using either a wired (ethernet) or wireless backhaul link to connect to the RG system.

Supported Topologies

Note: The GigaSpire BLAST u4hm Wi-Fi AP system operates in satellite mode only.

The GigaSpire BLAST u4hm Wi-Fi AP system can connect to the RG system via a wired or wireless connection. You can arrange satellites in a star or daisy-chain topology, adhering to the following guidelines:

- Maximum of (4) satellites supported per RG
- Star topology preferred; daisy chain topology also supported
- For star arrays, wired or wireless links to the RG are supported
- For daisy-chains, a maximum of 2 hops are supported (from RG to last satellite)
- For daisy-chains, only wireless backhaul links are supported

Satellite mode

When operating as a WAP satellite, the satellite system can connect to the RG system via a wired or wireless connection. You can arrange satellites in a star or daisy-chain topology, adhering to the following guidelines:

- Maximum of (4) satellites supported per RG
- Star topology preferred; daisy chain topology also supported
- For star arrays, wired or wireless links to the RG are supported
- For daisy-chains, a maximum of 2 hops are supported (from RG to last satellite)
- For daisy-chains, a single wireless backhaul link is available with a hard-wired ethernet link as well.

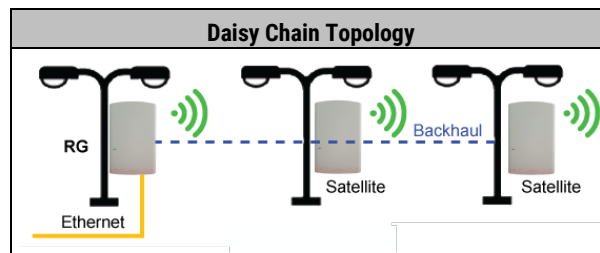
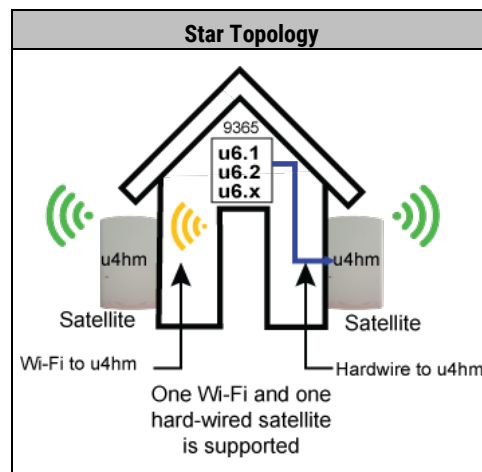

User-Supplied items

Bring the following tools and materials to the installation site, as required:

Materials

- An ethernet cable up to 100 m in length (for a wired uplink to the RG)
- Silicone sealant/caulk; for sealing cable entry holes
- (2) mounting screws for wall-mount bracket
- PoE power supply equipment (PSE)/PoE injector, to install nearby; only if using PoE power option

Tools

Bring the following tools to the installation site:

- Phillips head screwdrivers (#2 head, #1 head)
- Level for aligning the installed bracket to the wall or pole
- Pencil (to mark bracket and drill hole locations; wall-mount kit)
- Nut driver, 5/16" (to tighten hose clamps; pole-mount kit)

Chapter 2

Installing the GM1028H GigaSpire BLAST Satellite

In this section, the following topics are covered:

- *Unpacking* (on page 22)
- *Identifying the Installation Location* (on page 24)
- *Wall Mounting Dimensions and Instructions* (on page 26)
- *Optional: Pole Mounting* (on page 29)
- *Grounding the u4hm* (on page 33)
- *Installing Power and Network Cables* (on page 22)



CAUTION! Use of controls or adjustments or performance of procedures other than those specified here may result in hazardous radiation exposure.

MISE EN GARDE! L'utilisation de commandes ou de réglages ou l'exécution de procédures autres que celles spécifiées ici peuvent entraîner une exposition à des rayonnements dangereux.

Note: Before mounting the u4hm to a wall or pole, complete all internal wiring. Once the u4hm is attached, very little room exists due to mounting bracket interference.

Follow these tips when installing a GigaSpire BLAST GM1028H device:

- For subscribers using data services, all data wiring inside the home must be CAT5 cable or better.
- Make sure subscriber connections are tightened properly.

Check the contents of each box carefully as you receive them. Components may not be located where you might expect them due to certain items being tested immediately before shipment.

Unpacking the GigaSpire BLAST GM1028H

Each device is shipped individually in its own carton and contains the following:

Part Number 100-05839 GigaSpire Blast u4hm (GM1028H) hardened dual band 2x2 Wi-Fi 6, GE WAN includes the following additional parts and supplies:

- The u4hm main device with interface cover pre-installed.
- The wall mount bracket
- The grounding plug and the grounding screw (M4, Phillips head)
- Safety card

After opening the carton, remove the protective packaging, ensure all components above are present, and prepare for mounting the unit.

Before proceeding, the bottom cover must be removed.

In addition to the above, the following optional accessories are available (sold separately):

Part number 100-05967 GigaSpire BLAST u4hm (GM1028H), pole mount bracket kit

- Pole Mount Bracket
- Qty. 2 hose clamps for 2" to 6" diameter pole.
- Qty. 1 M4 Phillips head screw

Installing Power and Network Cables

Prior to installing cables, the bottom access cover must be removed.

Removing the access cover

1. Remove the access cover screws¹ using a Phillips head screwdriver. Set aside the screws for re-installation later.
2. With screws removed, grasp the cover and pull it up and away from the u4hm.

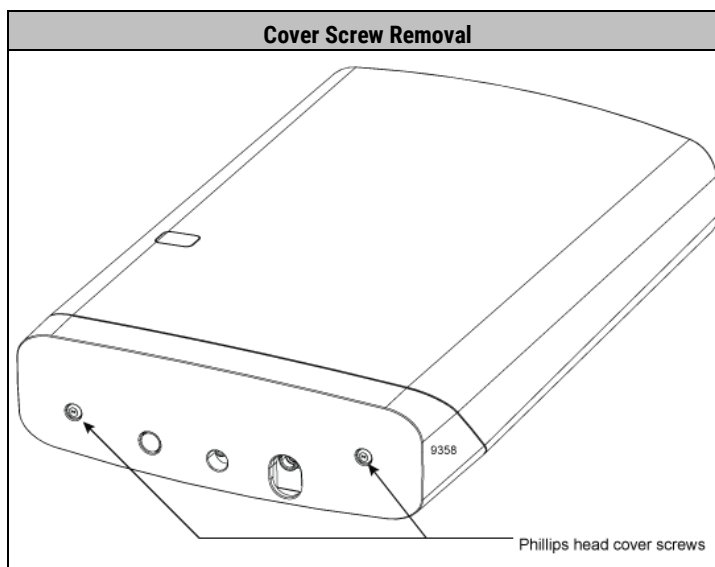

3. Set the cover aside for re-installation later.

¹ **Note:** Some early u4hm units shipped with tamper-proof Torx head screws instead of Phillips head screws. If your unit is so equipped, use a security Torx driver instead.



Preparing the cable entry

1. Route one or both of the following cables into the cable entry stub(s) that you will use, as needed.
 - Local AC/DC power input
 - WAN / PoE ethernet port
2. Route the incoming cable(s) up into the u4hm.

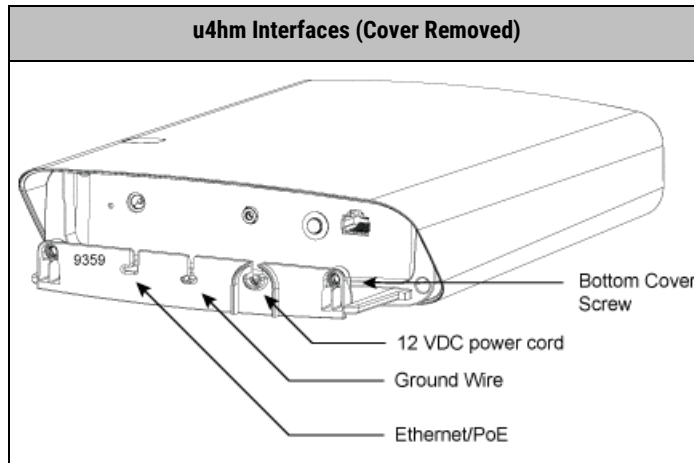

3. Connect the cable(s) to the u4hm cable interface port(s) as follows:
 - a. **Conditional - Power:** If this unit will use local commercial power, connect the power cable (from the AC/DC adapter) to the system's power input jack (2-pin barrel connector):
 - Feed the DC power cable through the hole in the right cable entry stub.
 - Connect the DC power cable to the power input jack.
 - Otherwise, if the system will use PoE power instead, skip to step 3b.
 - b. **Conditional Step - WAN:** If this unit will use a wired uplink connection to its RG and/or use PoE power, connect the ethernet cable.
 - Feed the ethernet cable through the hole in the cable entry stub (left-most slot).
 - Connect the ethernet cable to ethernet port (RJ-45 interface for LAN link).
4. Once complete, route cables down and away from the u4hm.
5. Dress any cables or cable bundles using clips or cable ties.

To achieve a complete seal, you can use silicone caulk around the cable entry area at the bottom of the cover. Seal the cable entry locations with silicone-based caulk as needed.

Identifying the Installation Location

Calix recommends mounting the u4hm as high as practical for Wi-Fi performance reasons. However, this deployment scenario still mandates that an AC power outlet is located within the power cord distance of the Wi-Fi source (optional 16' power cord is available for outdoor installations).

If installing in a greenfield environment (initial installation), plan on placing the u4hm within the provided (4 feet) length of the power supply cord. As an alternative, longer power cords are available to extend the distance between the GigaSpire BLAST and the power supply.

Before installing either device, consider what additional services may be implemented. Various access points are available on the bottom of the unit which may or may not be used. Prior to determining the unit's final location, you need to account for the following variables:

- Optional: Where will the ethernet cable(s) be routed?
- What type of building material is used in this facility? Make sure you have the appropriate drills, drill bits and fasteners for routing ethernet or power cables as they pass through walls and the like.

From a best practice's standpoint, keep the following in mind:

- Calix recommends keeping cabling neat and well secured wherever possible. A tidy installation allows for increased safety and an overall neater appearance. Common tools used for this purpose include cable ties and velcro straps for routing cable out of the way. Also, custom made wall plates are often used where most cabling is hidden behind a wall.

Wi-Fi AP placement

Direct line-of-sight to the Wi-Fi access point (AP) is not essential for client signal quality, thanks to MIMO technology and an omni-directional antennae array in the AP. However, to achieve the best possible Wi-Fi coverage and performance, Calix recommends the following guidance:

- Prioritize a centralized location; the closer the AP system is to the center of the serving area, the better.
- Elevate the system as high up as possible; higher elevation helps the signal clear lower/ground-level obstructions.

Some building materials block Wi-Fi signals more than others. See the table below for reference; lower attenuation yields better performance. Consider the materials in surrounding structures when selecting an installation location for the system.

Effects of Building Materials on Wi-Fi Signals

Material	Wi-Fi Attenuation
<ul style="list-style-type: none">• Wood, Drywall, Particle Board, Tile• Glass	Low
<ul style="list-style-type: none">• Bricks, Cinder Block• Water	Medium
<ul style="list-style-type: none">• Plaster, Stucco• Concrete	High
<ul style="list-style-type: none">• Metal• Tinted or Low-E Glass (metalized)	Very High



CAUTION! Use of controls or adjustments or performance of procedures other than those specified in this document may result in hazardous radiation exposure.

MISE EN GARDE! L'utilisation de commandes ou de réglages ou l'exécution de procédures autres que celles spécifiées ici peuvent entraîner une exposition à des rayonnements dangereux.

Installing the System on a Wall

Dimensions for wall mounting of a GigaSpire GM1028H are included here for reference.

Note: The GM1028H must be wall or pole mounted using the appropriate mounting bracket.

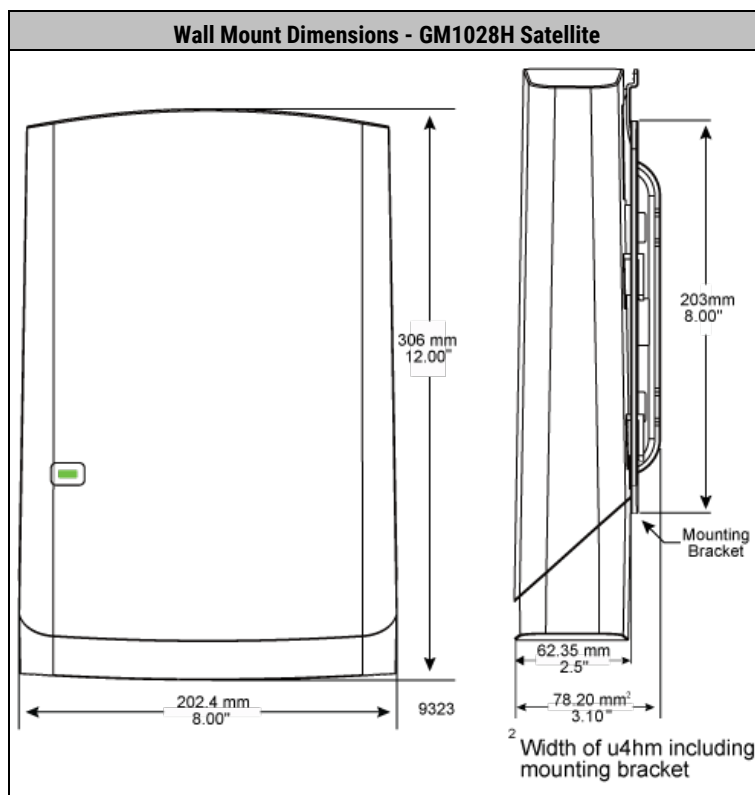

The Calix satellite GM1028H can be wall mounted. Keep the following information in mind when considering wall mounting:

- In a wall mount environment, the minimum distance between the u4hm and the ground is 3.3 meters (11 feet).

Note: Elevation helps APs achieve maximum Wi-Fi coverage per the system specification. The ideal mounting height above the ground for the u4hm is 3.3 meters (11 feet). Mounting the unit lower than this height is supported, but it may not achieve its maximum signal reach.

- Locate the unit on the wall in a location that is unlikely to be bumped or jostled.
- Make sure that the ethernet cable[s] (if used) and power supply wiring attached to the unit are secured properly and out of harms way.

Note: Once the GigaSpire is connected and turned up, Wi-Fi network parameters are persisted in memory. For this reason, if power is lost to the unit, it will be re-discovered on the network automatically, without operator intervention.

To wall mount the GigaSpire BLAST GM1028H

1. Find a suitable location for attaching the unit to the wall. Be mindful of the power source and ethernet cable requirements when determining a mounting location.
2. Using the illustrations below, mark the two screw locations on the wall, making sure the device will remain level after mounting.

Note: If attaching to sheet rock or gypsum board, Calix recommends using a wall anchoring system to ensure the bracket is securely attached.

3. Drill holes in the wall and install appropriate wall anchors if required.
4. Thread the screws into the wall anchors and tighten leaving a gap of about 1/8" between the screw head and the back of the unit. This gap allows the u4hm wall mount bracket to be slip fit over the mounting screws.

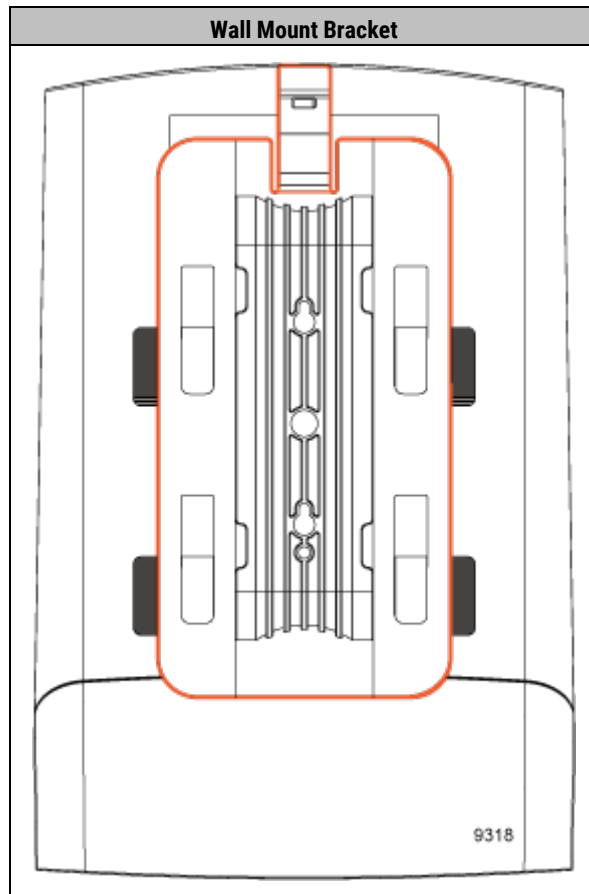

Before attaching the wall mount bracket to the back of the GM1028H, make sure the bracket has locked into place as directed below.

Mounting Bracket Dimensions

The GM1028H has a wall mount bracket included in the packaging. The bracket itself does not require any fasteners for attaching to the GM1028H however there are two mounting slots on the bracket for attaching to the wall. Appropriate mounting dimensions are shown here for reference.

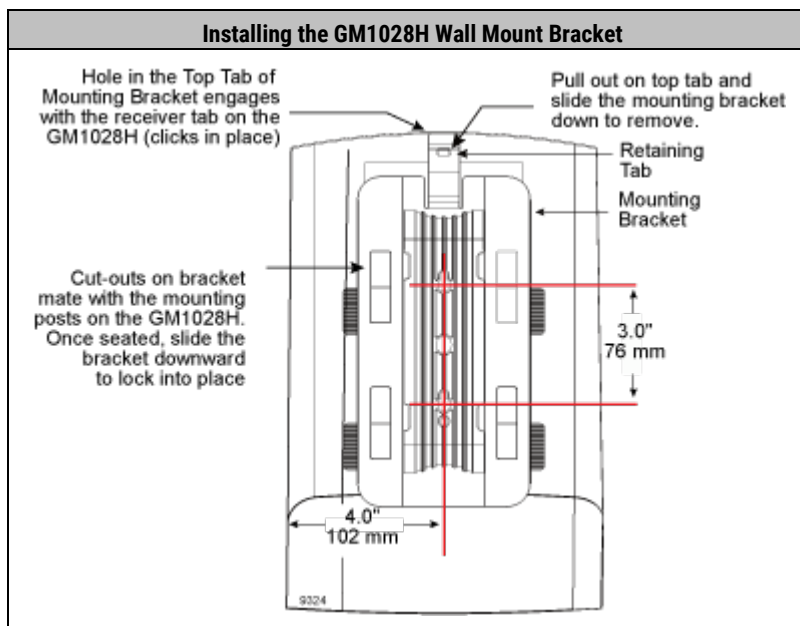

Installing the System on a Pole

The GigaSpire u4hm (GM1028H) can be pole mounted using an optional pole mount kit from Calix (100-05967). The kit consists of the following components:

- Pole Mount Bracket
- Bracket Hose Clamp (2)
- Ground Lug Cable assembly
- Screw, 8-32 x 1/2" Hex Head (4)

To pole mount the GM1028H

Note: The pole mount kit is designed to accommodate a round pole 2 to 6 inches in diameter. If you have a pole with diameter larger than 6 inches, you can daisy-chain 2 house clamps together for each band (requires 2 additional hose clamps, not supplied by Calix).

Note: In a pole mount environment, the minimum distance between the u4hm and the ground is 5 meters (16 feet). Elevation helps APs achieve maximum Wi-Fi coverage per the system specification. The ideal mounting height above the ground for the u4hm is 5 meters (16 feet). Mounting the unit lower than this height is supported, but it may not achieve its maximum signal reach. In most environments, mounting the u4hm lower than 5 meters will provide adequate Wi-Fi coverage.

1. Ensure you have a properly buried or secured pole.
2. Fix the pole mount bracket to the pole using the 2 provided hose clamps. The bracket can be on either left or right side of the pole.
 - a. Open both hose clamps as shown below.

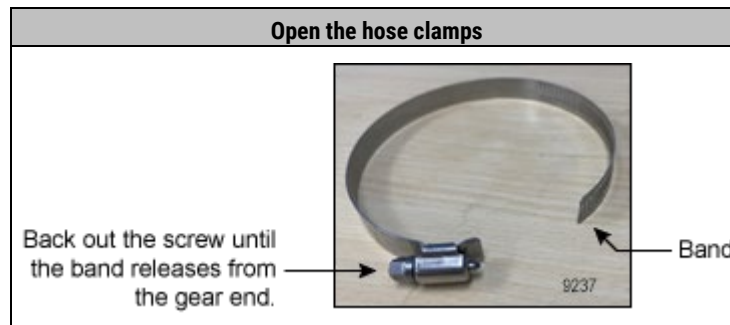

- b. Loop the two hose clamps through the mounting bracket as shown below.

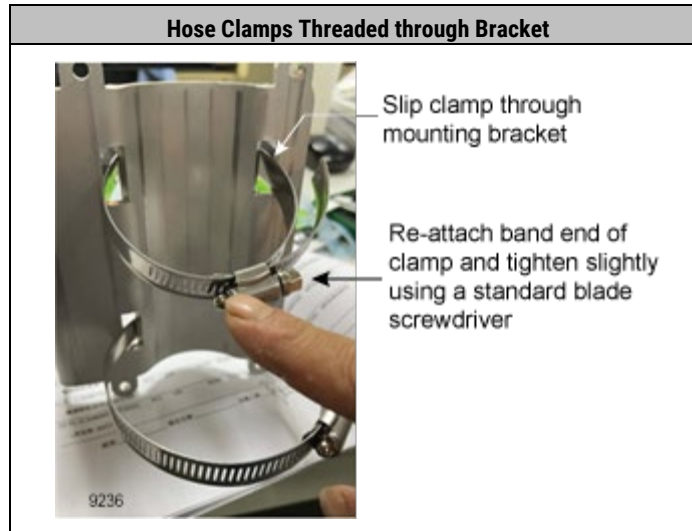

- c. Take the assembled pieces above and slip them over the attachment pole.
- d. Tighten the hose clamps until snug.

Note: The hex head screw on the hose clamp can accept a 5/16" ratchet bit for faster tightening.

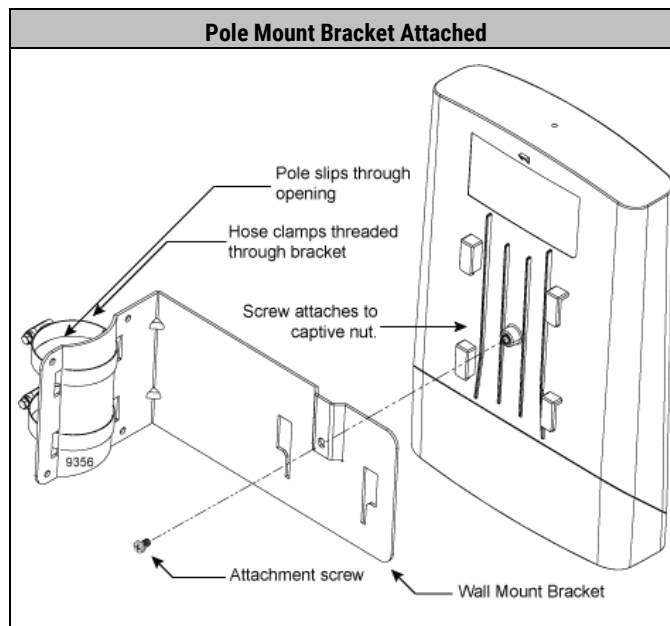

3. Attach the GM1028H system to the mounting bracket:
 - a. Before attaching the u4hm, orient the unit so its interfaces point downward.
 - b. Install and tighten two of the hex screws into the back of the u4hm remembering to leave about a 3/16" gap between the screw and the u4hm cut-out.
 - c. Hang the device onto the pole mount bracket and tighten/adjust the screws so the u4hm is snug but not overly tight.
4. Prepare the cable entry location (bottom).
5. Route the incoming cable(s) up the pole to the mounting location and connect to the u4hm as follows:

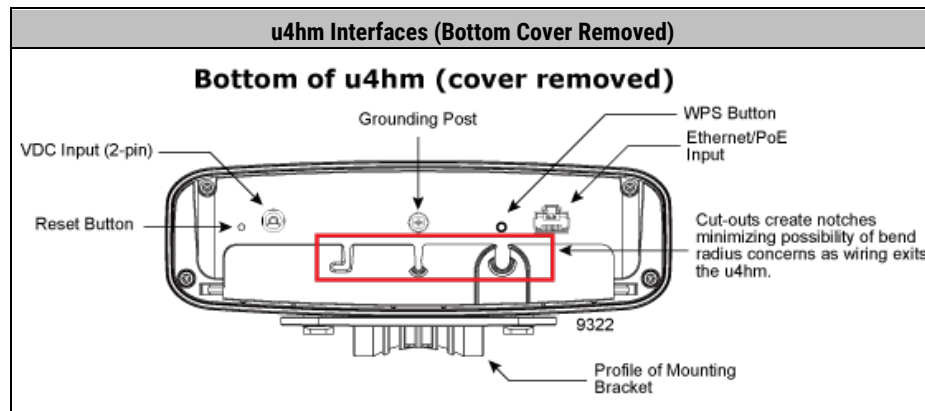

- a. Connect the WAN ethernet cable (from the upstream ONT or PoE switch):
 - Feed the ethernet cable through the right-hand cut-out in the cable entry stub (# 3 raceway above).
- b. **Conditional Step:** If using commercial power, connect the DC power cable (from the AC/DC adapter):
 - Feed the DC power cable through the 'x' hole in the right cable entry stub (#3 in image above).
 - Connect the DC power cable to the power input jack.
- c. **Conditional Step:** If this unit provides a wired LAN connection or a daisy-chained link to another u4hm unit, connect the LAN ethernet cable:
 - Feed the ethernet cable through the 'x' hole in the left cable entry stub (#1 in image above).
 - Connect the ethernet cable to ethernet port '1' (RJ-45 interface for LAN link).
6. Once complete, route cables directly to and against the mounting pole and secure with cable ties or other material as appropriate per local codes.
7. Seal the cable entry locations with silicone-based caulk as needed.

Grounding the Unit

For equipment protection in high lightning areas, establish a ground connection for the u4hm chassis before putting it into service.

Use a 20 AWG wire (not provided) for grounding. Connect the ground wire to the u4hm chassis using Calix supplied hardware (ring lug and Phillips pan-head screw with pawl washer) as described below.



ALERT! Beware of electrostatic discharge. Follow standard ESD precautions. Always wear a grounded ESD wrist strap to avoid damaging the electronic equipment.

To ground the u4hm chassis

1. Get a user-supplied 20 AWG ground wire and cut the wire to the required length.
2. Crimp the supplied ring lug onto the ground wire end.
3. Connect the ground wire to the u4hm chassis as follows:
 - a. Fit the ground wire's ring lug over the ground terminal post hole.



- b. Insert the provided ground screw into the chassis ground terminal. Turn the screw until fully seated.
 - c. Tighten the screw to 27 in-lbs. of torque.
4. Route and terminate the ground cable to the ground connection point.



Chapter 3

Final Setup and Activation

This chapter describes how to activate the GM1028H system for service.

Topic Covered

This chapter covers the following topic:

- *Powering up the System* (on page 35)
- *Replacing Removed Covers* (on page 37)
- *Sealing Cable Entry Locations* (on page 37)

Powering Up the System

After you have installed cables, the GigaSpire u4hm (GM1028H) system is ready to power up and connect to the network.

Use one of the following procedures to apply power to the system.

- If you installed a Calix power adapter cable* to use a local AC power supply, follow the first procedure below.
- If you installed just an ethernet cable* to use a PoE supply, follow the second procedure below.

*Note: Refer to "Installing Power and Network Cables" for details about installing these cables.

Local power (AC/DC adapter)

To apply local power to the system

1. Verify that the Calix-supplied power cable (installed previously*) is connected to the u4hm power input.
2. Route the power cable's far end to the nearest 110/220 VAC wall outlet and plug its 3-prong connector into the outlet.
3. Observe as the system powers up and begins its start-up sequence (Flashing green LED). Refer to "System LED Behavior" for expected behavior.
4. Dress and secure the power cable outdoors as appropriate.



PoE power (ethernet cable)

To apply PoE power to the system

1. Verify that an ethernet cable (installed previously) is connected to the unit's WAN ethernet port.
2. Route the ethernet cable's far end to the PoE injector power from the PoE injector and connect it to a LAN-side port.
3. If the PSE (injector) is not already powered up, apply power to the PSE so that it can supply the PoE line feeding the u4hm system. Otherwise, skip to step 4.
4. Verify that an ethernet cable is installed between the PoE injector (WAN side) ethernet port and a LAN port of the GigaSpire BLAST RG system.
5. Observe as the u4hm powers up and begins its start-up sequence (Flashing green LED). Refer to "System LED Behavior" for expected behavior.
6. Dress and secure the outdoor ethernet cable as appropriate.

Next steps

Before completing the installation, verify system startup operation:

- Verify that the system LED shows as "in service". Refer to "System LED Behavior" for expected behavior.
- Verify with your back office that the system checked in to Calix Cloud as needed.

Replacing Removed Covers

Covers must be replaced before finalizing the installation. Perform the following steps:

1. With the power, ethernet, and ground wires securely connected, thread each exit cable through the provided bottom stub of the u4hm.
2. Use additional cable ties or wiring clips to dress the cables outside the u4hm.
3. Place the previously removed lower cover into the slots of the u4hm and re-install the torx screws.

Sealing Cable Entry Locations

Depending on the power and network uplink options you selected, each installed u4hm unit may terminate from one to three cables.

You must seal the cable entry location(s) to protect the interior electronics against moisture, dust, pests, and other contaminants. Use a silicon-based sealant or comparable compound.

Note: Seal all cable entry ports immediately after installation to prevent moisture from condensing inside the access compartment, which may cause damage. This practice is critically important in humid regions.

To seal the cable entry port(s)

1. Verify that the access compartment cover has been re-attached to the bottom of the u4hm chassis. See *Replacing the Access Cover* (on page 37) for details.
2. Very gently pull on the cable(s) to eliminate excess slack inside the entry port(s), assuring a snug fit inside the port cutouts.
3. Apply silicone sealant to space around the cable in each entry port. If necessary, use a finger to spread the caulk around the rubber entry hole to assure a complete air-tight seal.

Appendix





System LED Behavior

EXOS system LED behavior is defined below.

Startup LED Behavior

LEDs on the front surface of the unit provide information on the status and current state of the device. Below, you will find a detailed status of the power-up cycle.

Note: Based on the model being deployed, LED size and/or orientation may be different (however behavior is unchanged).

Status	Function	Color
Off	Power is off. <ul style="list-style-type: none"> The unit has not been turned on, or There is no power to the unit Note: LED is off.	 Solid Gray (Off)
Booting Up, Software Upgrade in Process	Unit is in the boot-up process or service/software is being upgraded. Flashes orange every second assuming software has taken over. Note: LED is on.	
Boot-up Failure	Boot-up failed (assuming software has taken over) Note: LED is on. Cycles at 8/10 of a second	
Connected to internet	Unit has successfully booted up; local services are up and connected to the internet. Note: LED is on.	 Solid Green
Service Failure, No internet	No service, no internet.	 Solid Red

LED Behavior: WPS Functionality

Pressing the WPS button once initiates the primary pairing mode (allows mobile Wi-Fi clients to connect to the RG).



Pressing and holding the button for three seconds initiates Wi-Fi backhaul pairing mode (allows Wi-Fi satellites to connect to the RG).

After pressing the button, the WPS feature stays in pairing mode for 120 seconds. During this time, you can pair Wi-Fi client devices or satellites to the RG by also using the WPS function on those devices or systems.

Sequence of WPS operation

1. Press the WPS button a single time (or hold 3+ seconds in a 10-second window). The RG enters pairing mode for up to 120 seconds.
2. If another WPS device is found, the system pairs with the device. If no found, the system exits pairing mode after 120 seconds.

Note: Based on the model being deployed, LED size and/or orientation may be different (however behavior is unchanged).

Mesh Satellite Mode			
Mesh	WPS Pressed, pairing attempt has begun	<ul style="list-style-type: none"> * For Satellite/Mesh mode, upon pressing the WPS button a single time (3+ seconds), WPS is enabled. * The LED bar begins to flash 0.5 second green/off and continues to do so for up to 120 seconds. * If the Gateway has also initialized WPS during this time, the Satellite can be paired to the Gateway Wi-Fi radios (5.0 GHz band) thereby creating an association with the Gateway SSID. 	 <p>Off and green (1000 msec)</p>
	Gateway Not Found	<ul style="list-style-type: none"> * If no device is found after the initial 120 second time-out, the WPS/Strength LED bar shifts from the blinking Green to solid Red. * LED bar remains red for another 60 seconds, then revert to the <i>No internet failure</i> status. * If pairing is accomplished, LED bar will change to reflect Gateway status. 	 <p>Solid Red</p>
	Mesh Complete.	In Service. Connected to internet	 <p>Solid Green</p>

System Specifications

Hardware specifications for the GM1028H system follow:

Dimensions	Value
Width	10.75 in (27.3 cm)
Height	10.75 in (27.3 cm); 10.9 (27.7 cm) with cable boot
Depth	3.65 in (9.27 cm)
Weight	4.6 lbs. (2.1 kg)
Powering and Alarms	Value
AC / DC	Ext. Power Adapter (20 ft/6 m): 12 VDC, 3A 2-pin barrel connector (not included, ordered separately) Input voltage: 12 VDC (nominal), 10 VDC (min.), 15 VDC (max)
PoE	PoE 802.3at PD
Network Interfaces	Value
WAN/LAN	Single 1GE port; supports PoE 802.3at PD
Wireless	Dual band internal antennas (2x2 2.4 GHz, 2x2 5 GHz simultaneous) <ul style="list-style-type: none"> • 2.4 GHz 802.11 AX/N/G • 5 GHz 802.11 AX/AC/N • 2x2 UL/DL MU-MIMO, Explicit high-power, dynamic beamforming Wi-Fi Alliance Certified 802.11ax
Environmental	Value
Operating temperature	Indoor ambient temperature: -40° degrees C* to 70° degrees C (-40° F to 158° F)
Operating and storage relative humidity	10 to 90% and 5 to 95% non-condensing respectively
K.21 enhanced lightning support	*If the system is deployed in environments with temperatures below -30 degrees C, Calix recommends first starting the system in a warmer environment and run for 10-15 minutes. Once running, the system can function in temperatures down to -40 degrees C / -40 degrees F.
Certification and Compliance	Value
Emissions	FCC Part 15 Class B, Industry Canada (IC), ICES-003 Class B, CISPR-22
Safety	UL 62368 and UL 1697 approved